

## SUITE 220

SUITE FLOOR  
LOCATION

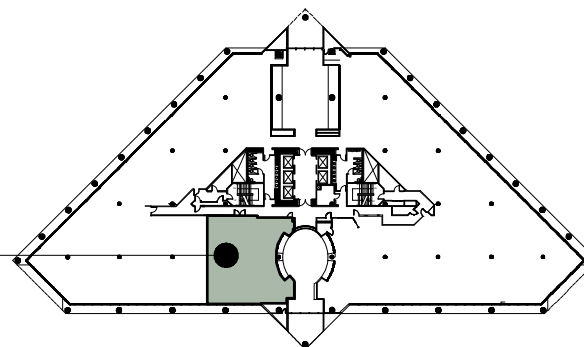

SECOND FLOOR KEY PLAN

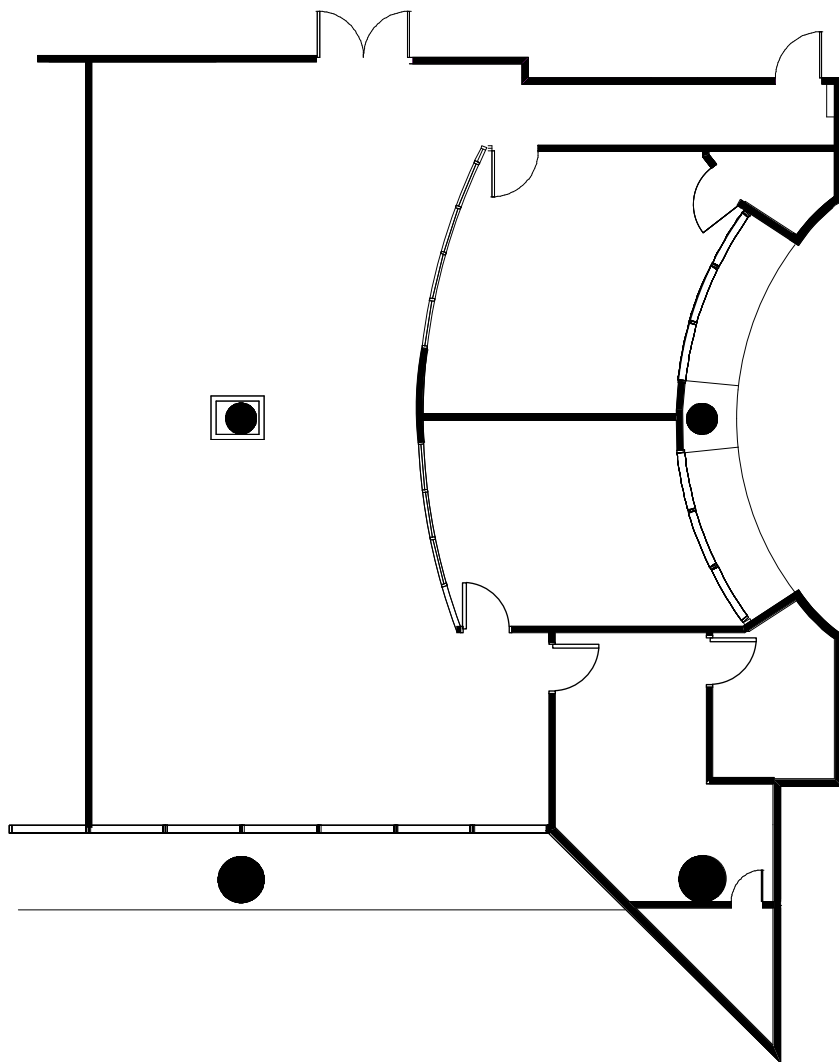

Colliers International  
1850 Mount Diablo Boulevard, Suite 200  
Walnut Creek, CA 94596 | United States  
[www.colliers.com](http://www.colliers.com)

LEASING AGENT

**Scott Ellis**  
(925) 279-5575

[scott.ellis@colliers.com](mailto:scott.ellis@colliers.com)

**Matt Hurd**  
(925) 279-5567

[matt.hurd@colliers.com](mailto:matt.hurd@colliers.com)

**Eric Erickson**  
(925) 279-5580

[eric.erickson@colliers.com](mailto:eric.erickson@colliers.com)

## Concord Gateway II

1855 Gateway Blvd.  
Concord, CA 94520

Second Floor

Owned and Managed by

**Sierra Pacific  
Properties, Inc.**

Approximate Area Calculations  
Subject To Verification:

2,670 rsf

As-built Plan To Be Verified

This information displayed while not guaranteed has been secured by sources we believe to be reliable. This information is subject to errors & omissions. Any tenant should conduct their own investigation.

Plan Revision - 2-5-18